

THIS REGISTERED DESIGN IS THE PROPERTY OF PSG AND IS NOT TO BE REPRODUCED, DISCLOSED TO A THIRD PARTY OR COPIED WITHOUT PRIOR WRITTEN PERMISSION.

# STOCK OFFERING - PRELIMINARY

REVISION			
REV	DESCRIPTION	REV BY	DATE

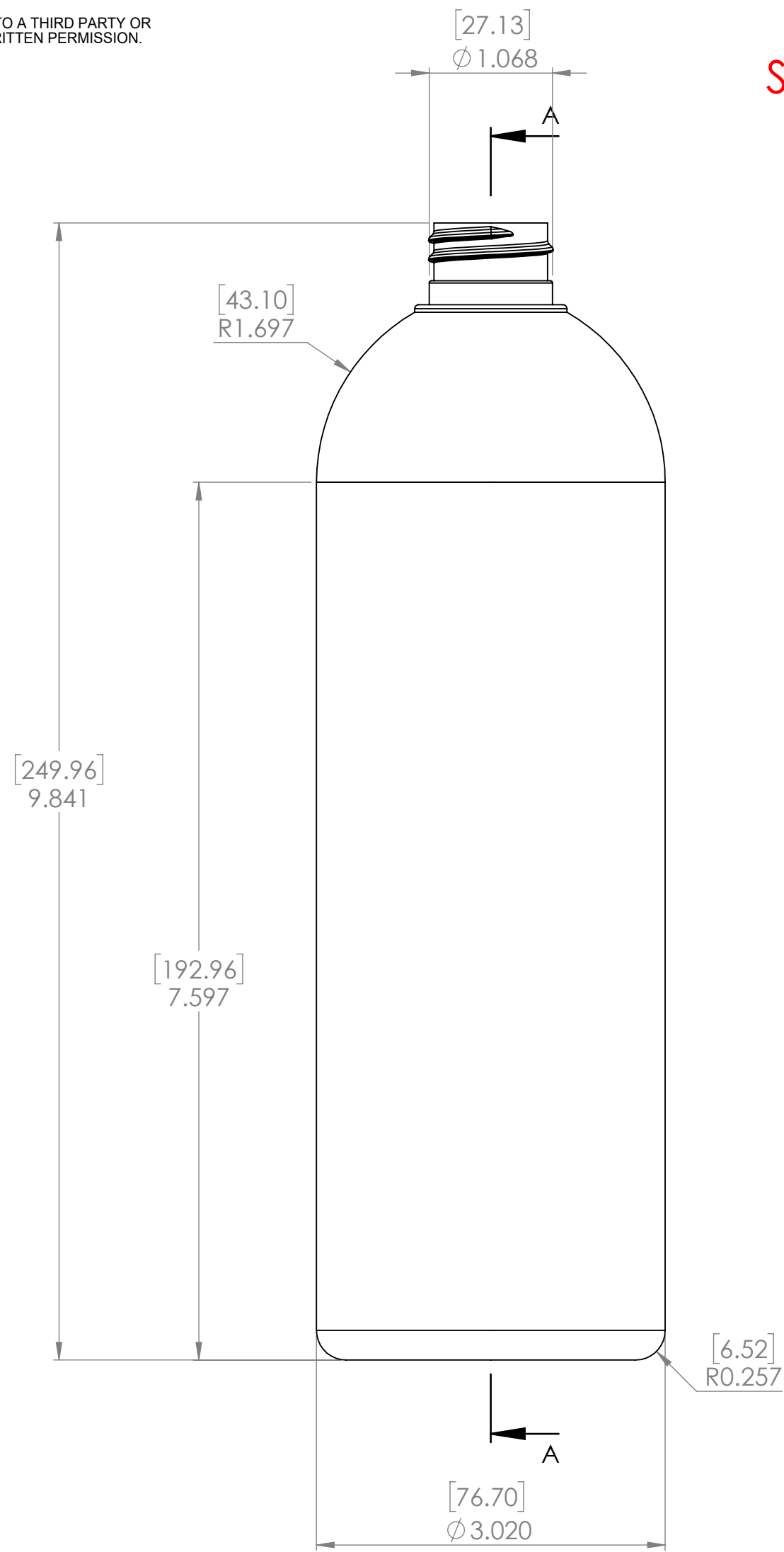

NOTE:  
 • NECK FINISH IS SPI 28-410

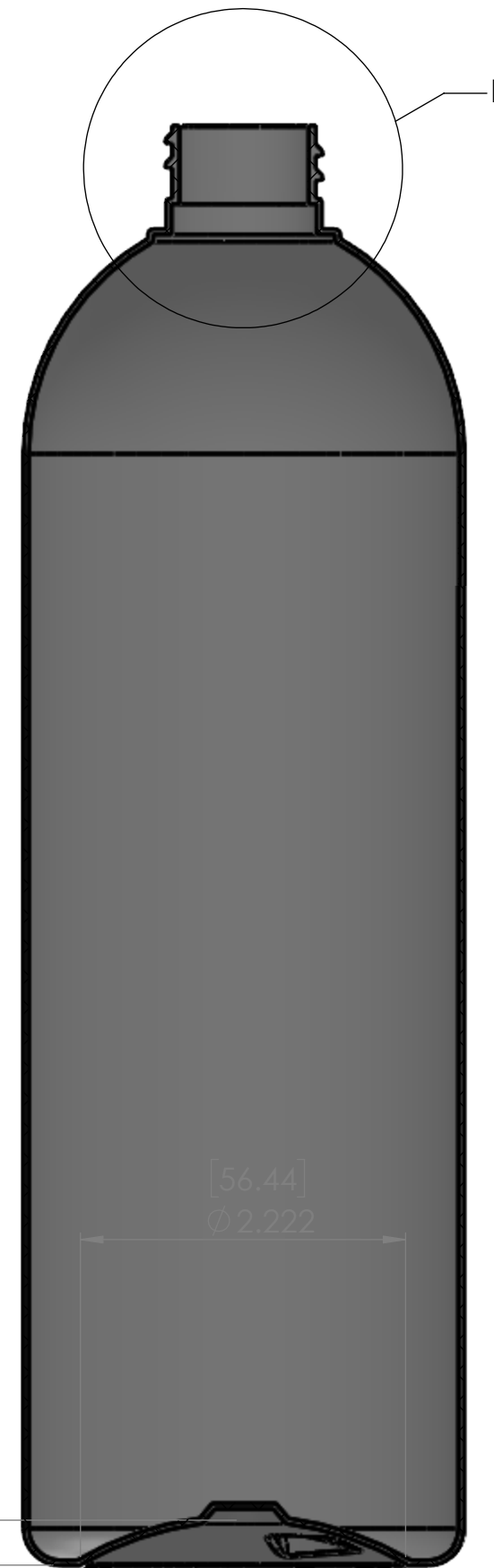

SECTION A-A  
SCALE 0.85 : 1

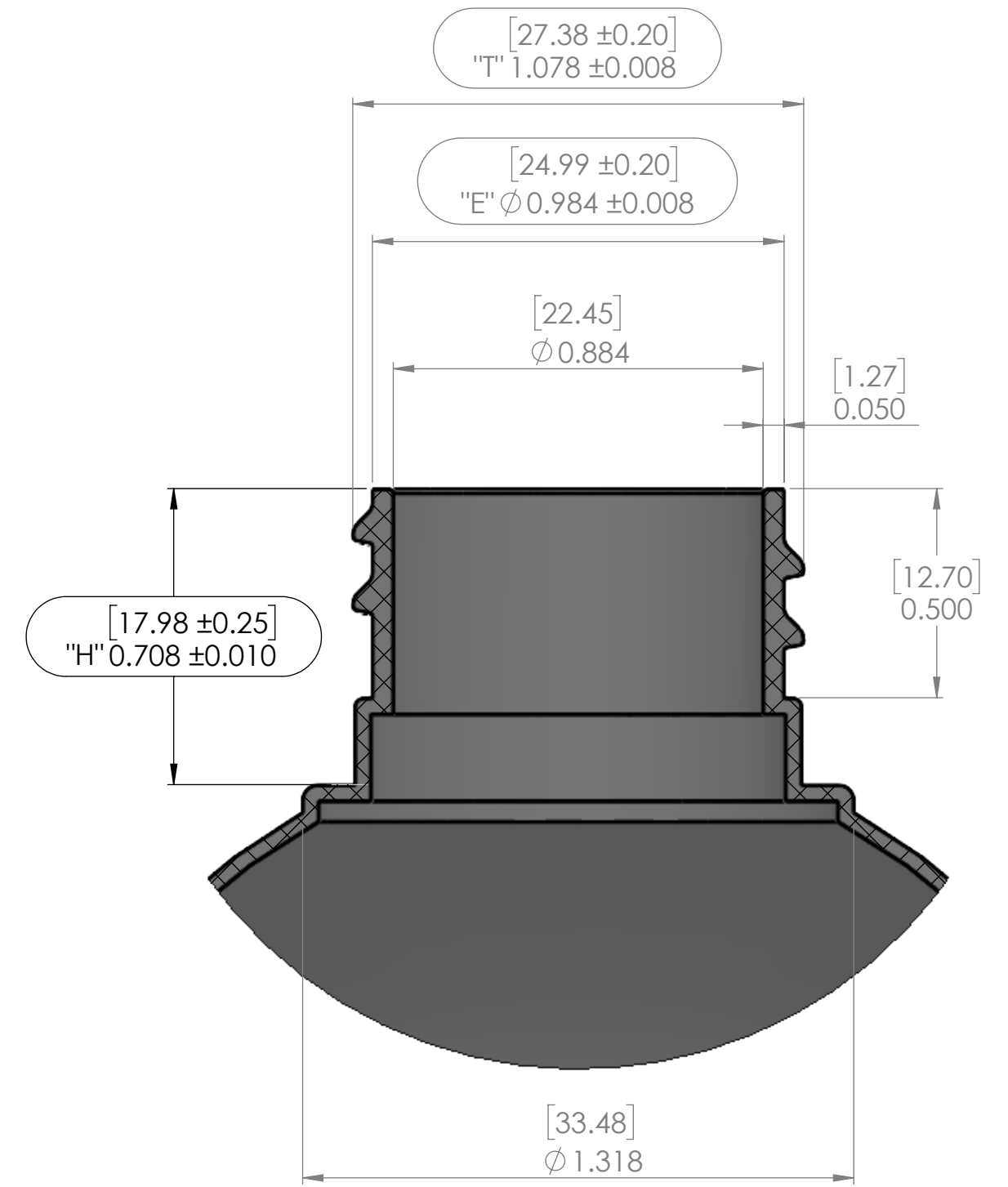

DETAIL B  
SCALE 2 : 0.75

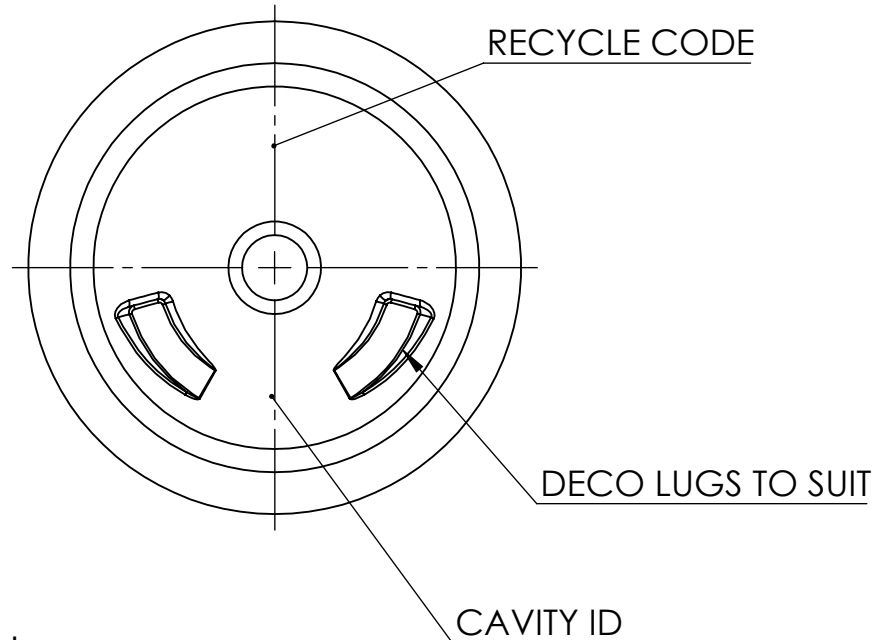

- Notes:
1. Dimensions in parenthesis are in millimeters.
  2. 1 Degree TPS (Taper Per Side) inside and outside unless otherwise specified.
  3. Minimum Radius R0.005 [0.13] all sharpe edges unless otherwise specified.
  4. Engrave all cavity ID numbers in 6 PT STD x 0.003 [0.08] deep in specified location or cavity ID marks to be vapor blasted on stripper ring @ 0.010 [0.25] maximum width.
  5. Bordered dimensions are QC (Quality Control) dimensions.
  6. All surfaces to be SPI A-2 High Polish

GENERAL TOLERANCES UNLESS OTHERWISE SPECIFIED:		NAME	DATE
< .200	± .003	DRAWN	C.WILLIS 4-20-20
.200 - .600	± .004	CHECKED	
.600 - 2.000	± .006	ENG APPR.	
2.000 - 4.000	± .008	MFG APPR.	
> 4.00	± .012	Q.A.	

WEIGHT	46g +/-1.5g	MATERIAL	PET	TITLE:	32oz BULLET ROUND
OFC	972ml +/-15ml	FINISH	DO NOT SCALE DRAWING	SIZE	DWG. NO. C PSG20-053-11
				SCALE: 1:2	SHEET 1 OF 1

