

THIS REGISTERED DESIGN IS THE PROPERTY OF PSG AND IS NOT TO BE REPRODUCED, DISCLOSED TO A THIRD PARTY OR COPIED WITHOUT PRIOR WRITTEN PERMISSION.

REVISION

REV	DESCRIPTION	REV BY	DATE

Preliminary STOCK OFFERING

- NOTE:
- NECK FINISH IS SPI 24-410
 - 1.5 TURNS THREAD REQUIRED

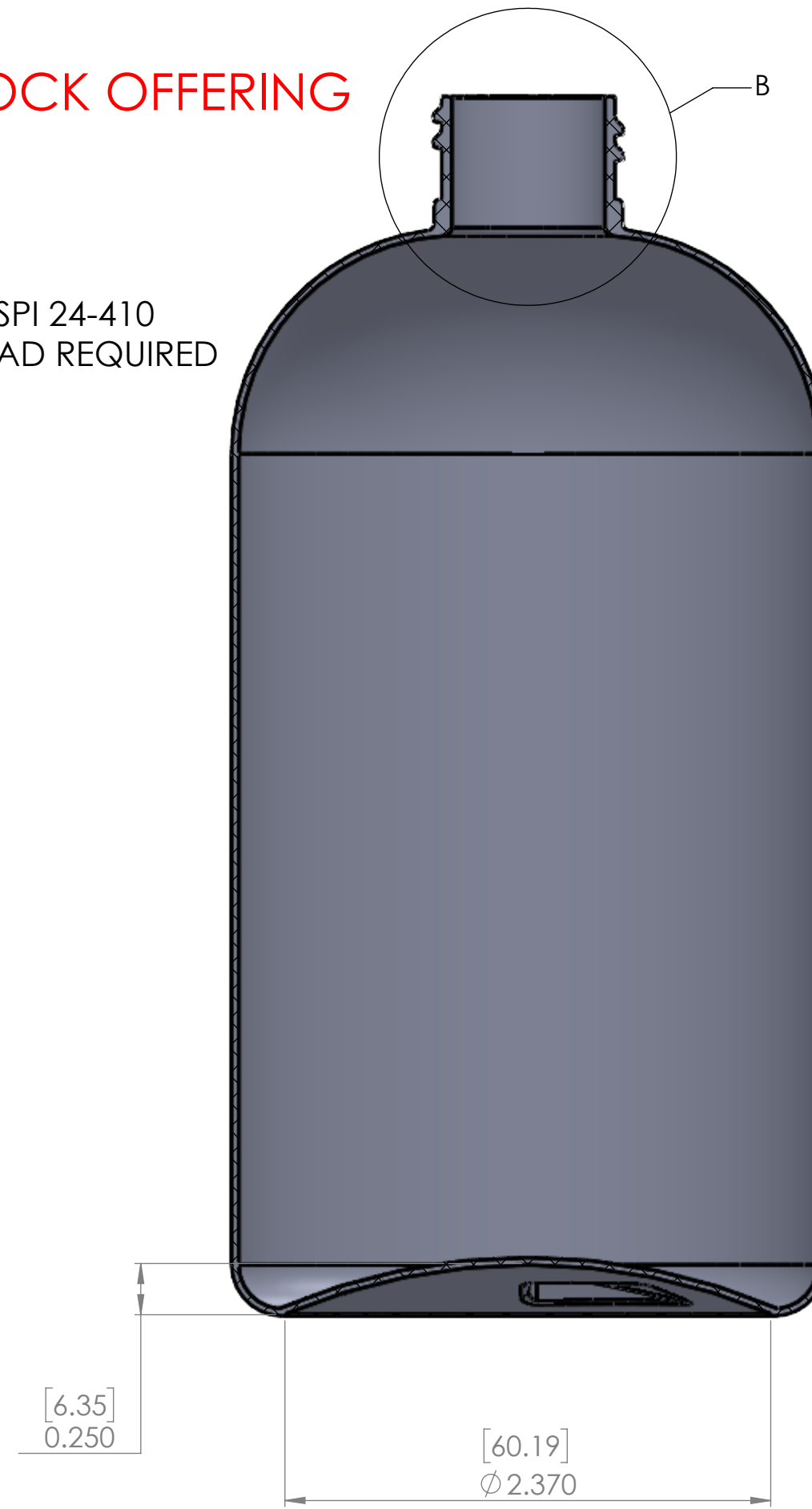
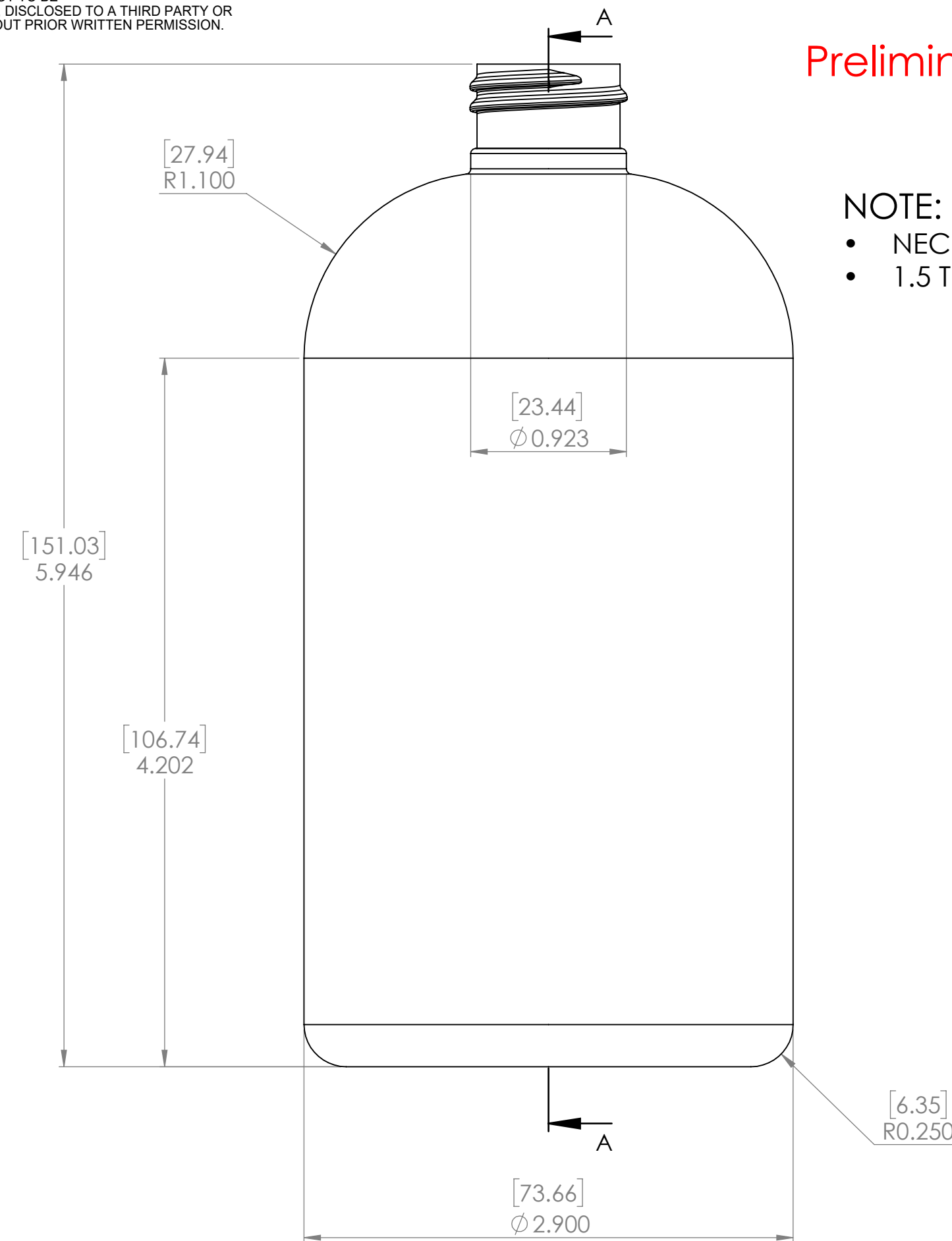

SECTION A-A
SCALE 1 : 0.75

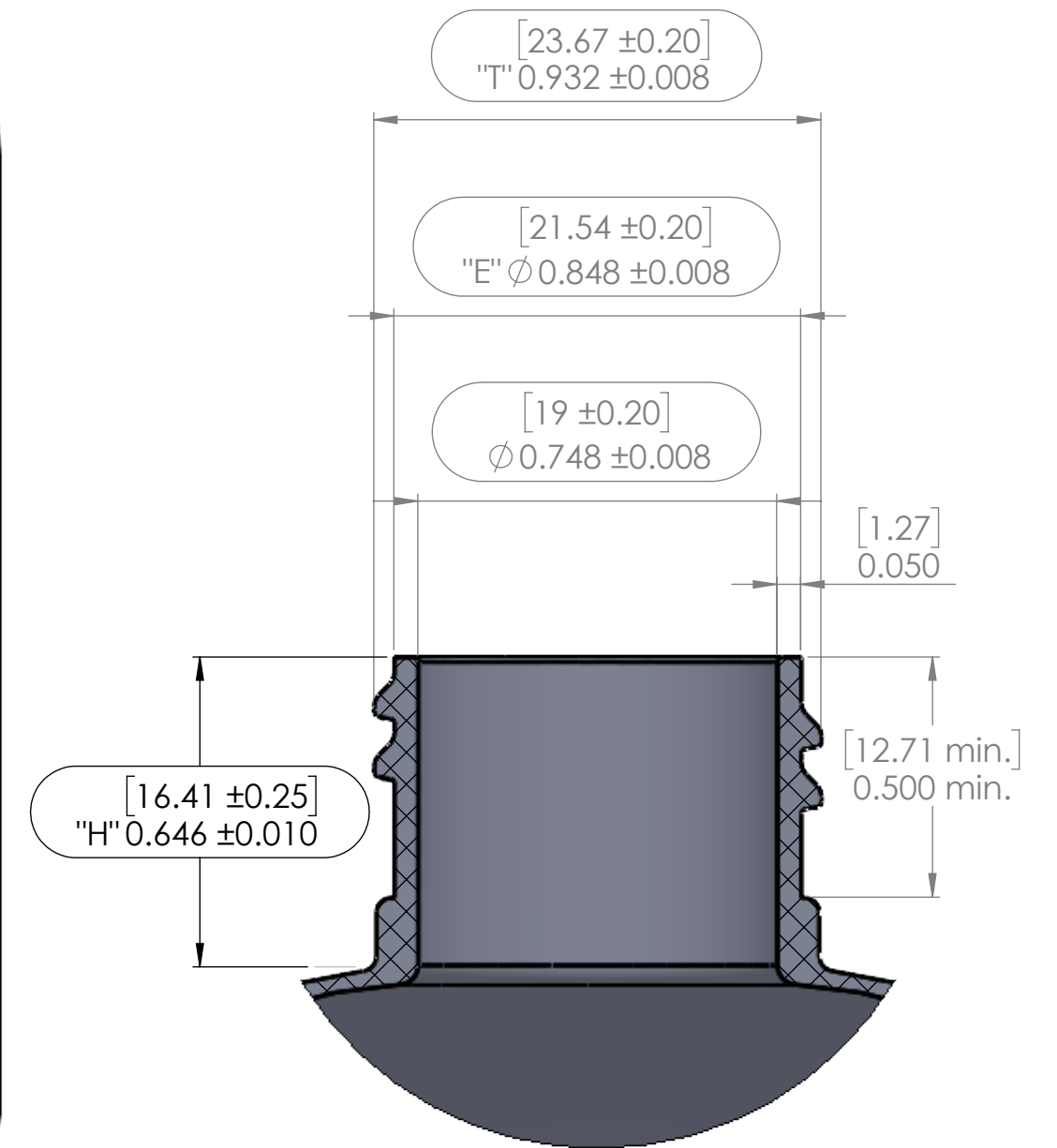

DETAIL B
SCALE 2 : 0.75

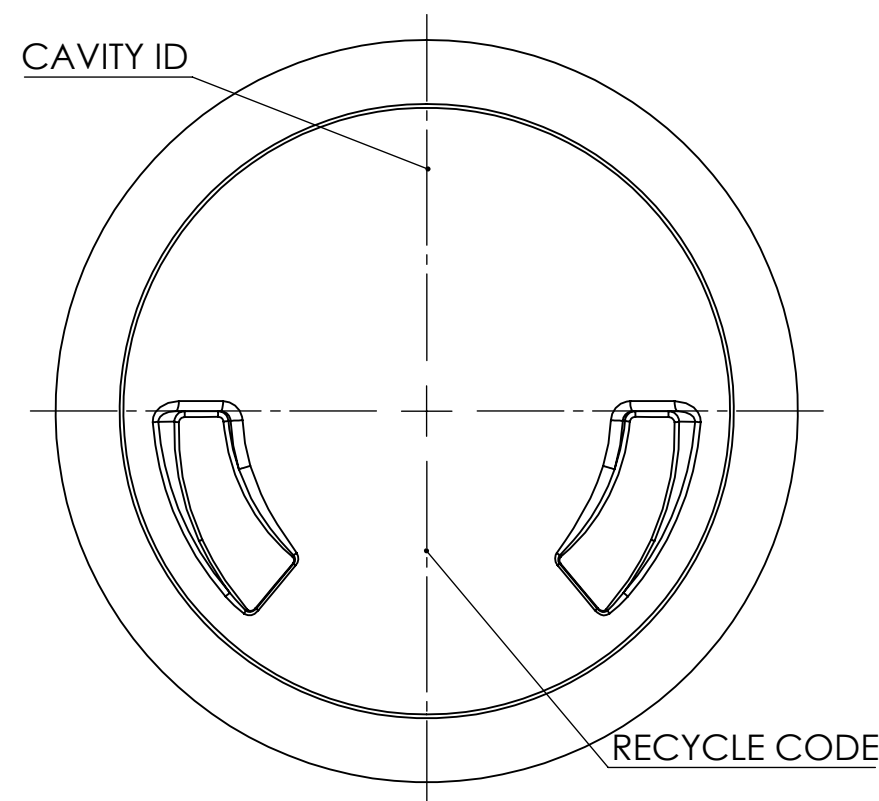

- Notes:
1. Dimensions in parenthesis are in millimeters.
 2. 1 Degree TPS (Taper Per Side) inside and outside unless otherwise specified.
 3. Minimum Radius R0.005 [0.13] all sharpe edges unless otherwise specified.
 4. Engrave all cavity ID numbers in 6 PT STD x 0.003 [0.08] deep in specified location or cavity ID marks to be vapor blasted on stripper ring @ 0.010 [0.25] maximum width.
 5. Bordered dimensions are QC (Quality Control) dimensions.
 6. All surfaces to be SPI A-2 High Polish

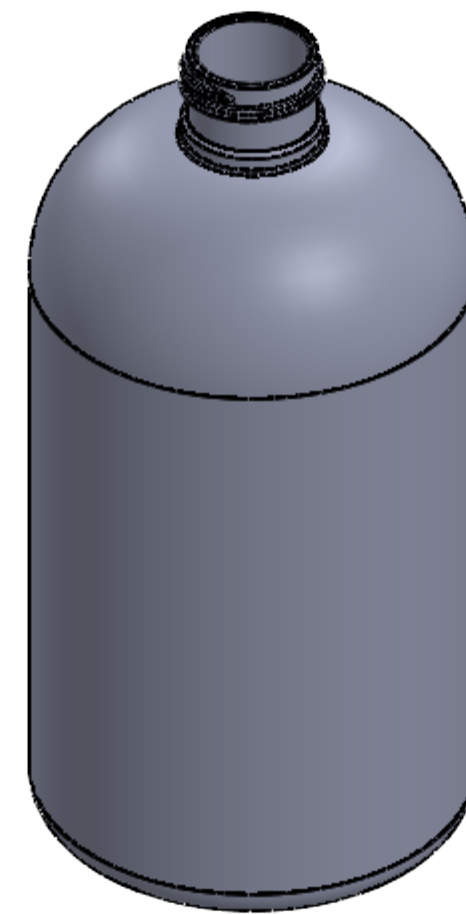

GENERAL TOLERANCES UNLESS OTHERWISE SPECIFIED:		NAME	DATE
< .200	± .003	DRAWN	C.WILLIS 11-24-20
.200 - .600	± .004	CHECKED	
.600 - 2.000	± .006	ENG APPR.	
2.000 - 4.000	± .008	MFG APPR.	
> 4.00	± .012	Q.A.	

WEIGHT	25g +/-2g	MATERIAL	PET	TITLE:	16oz BOSTON ROUND	SIZE	DWG. NO.
OFC	519ml +/-11ml	FINISH				C	PSG20-051-11
DO NOT SCALE DRAWING						SCALE: 1:2	

PSG

SHEET 1 OF 1