

THIS REGISTERED DESIGN IS THE PROPERTY OF PSG AND IS NOT TO BE REPRODUCED, DISCLOSED TO A THIRD PARTY OR COPIED WITHOUT PRIOR WRITTEN PERMISSION.

REVISION			
REV	DESCRIPTION	REV BY	DATE

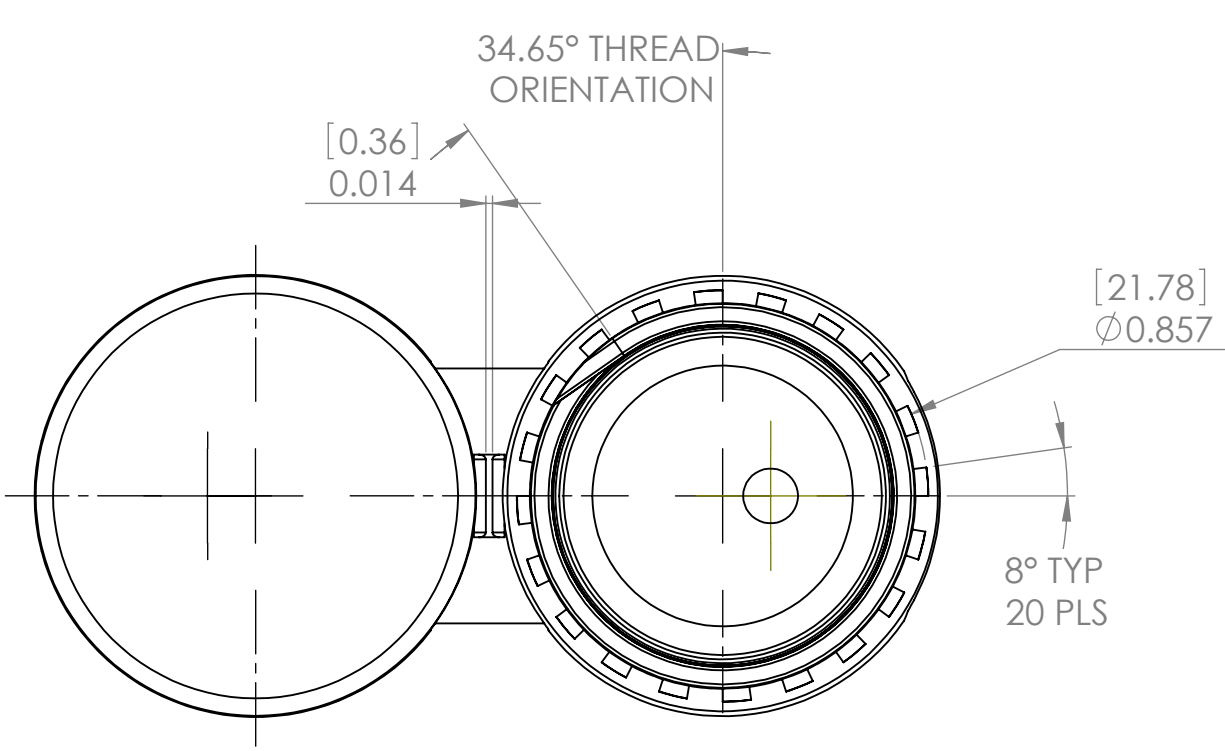
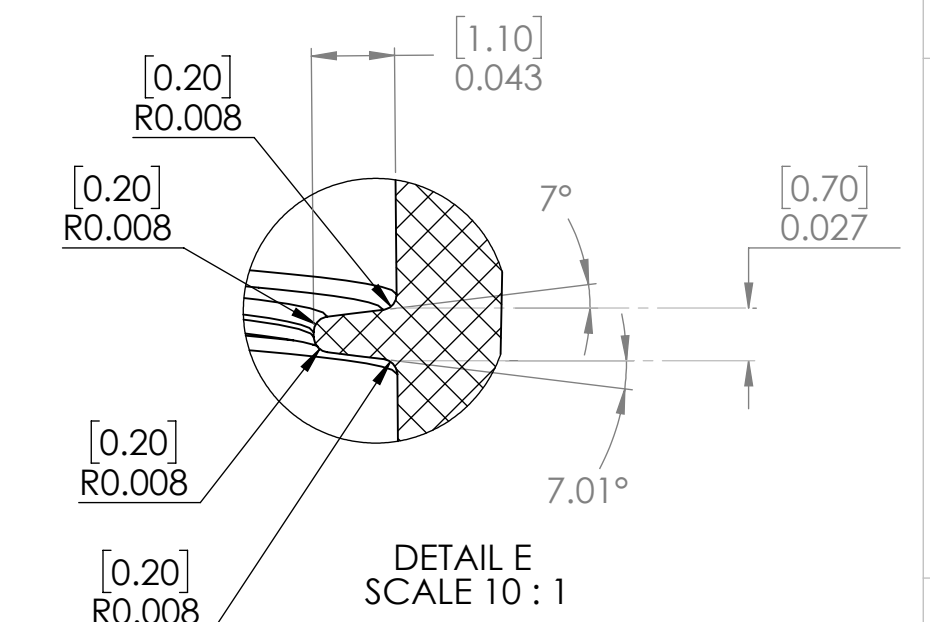
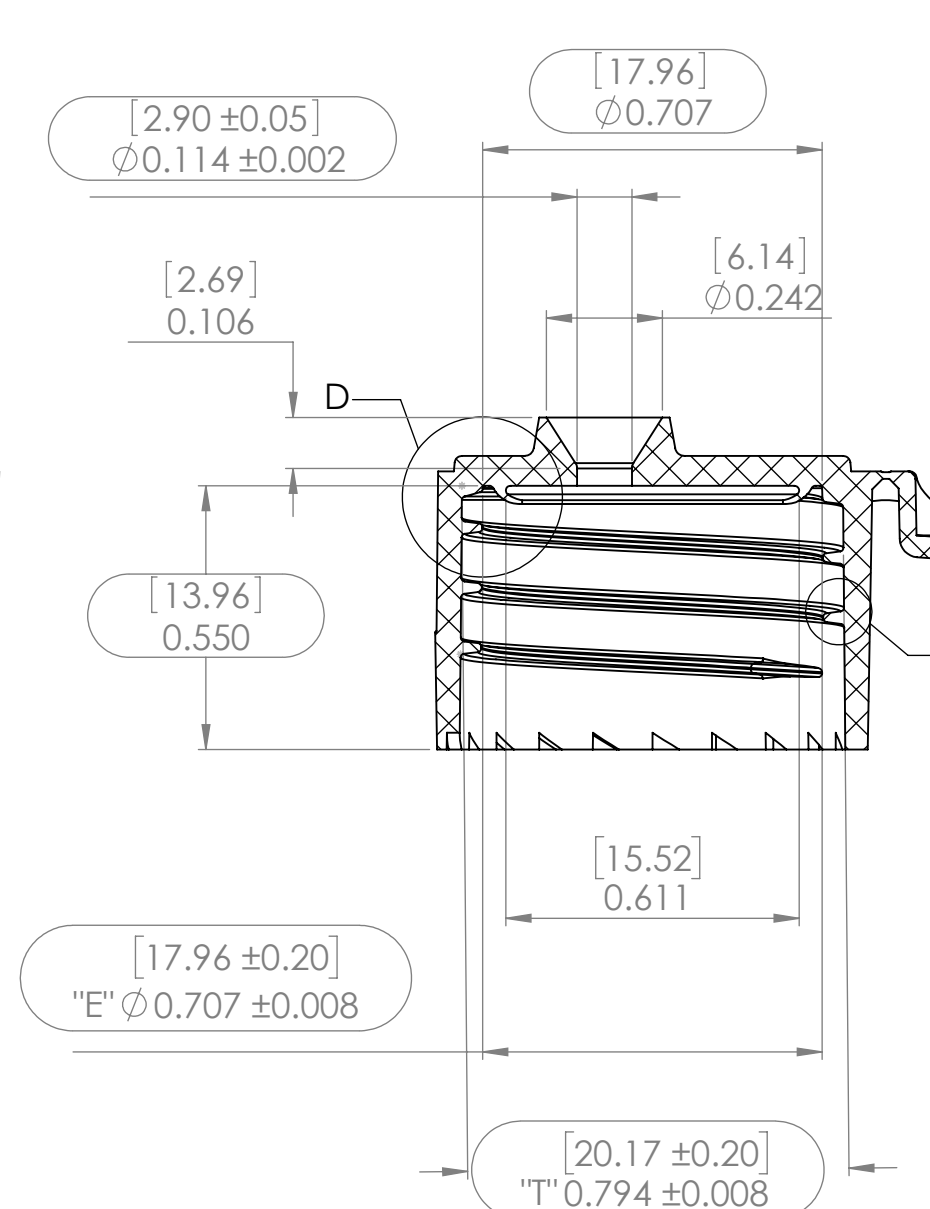
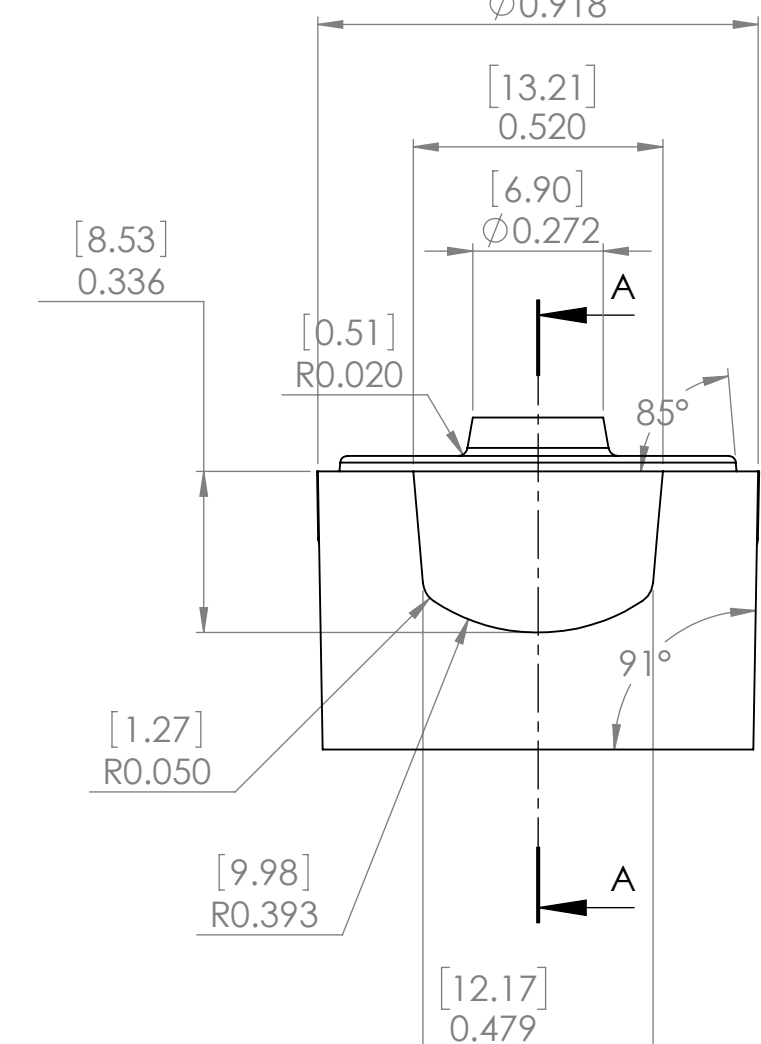
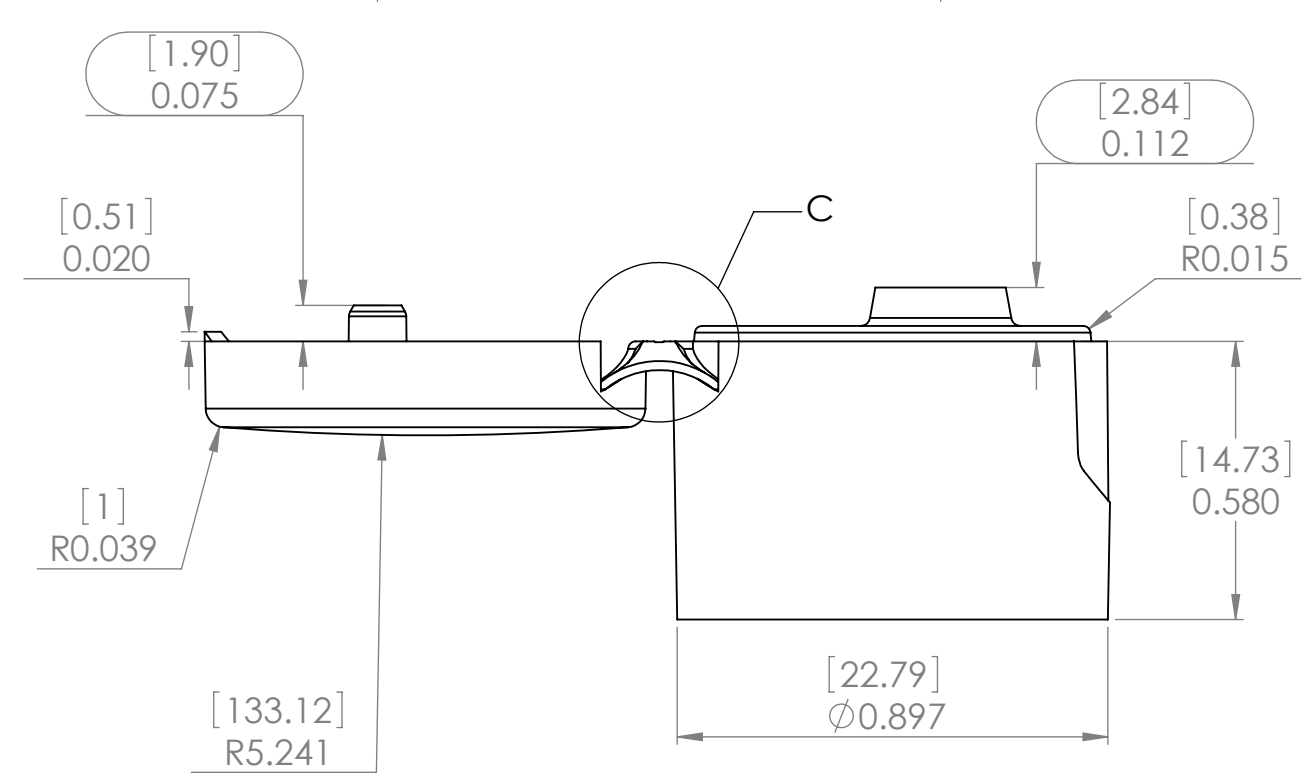
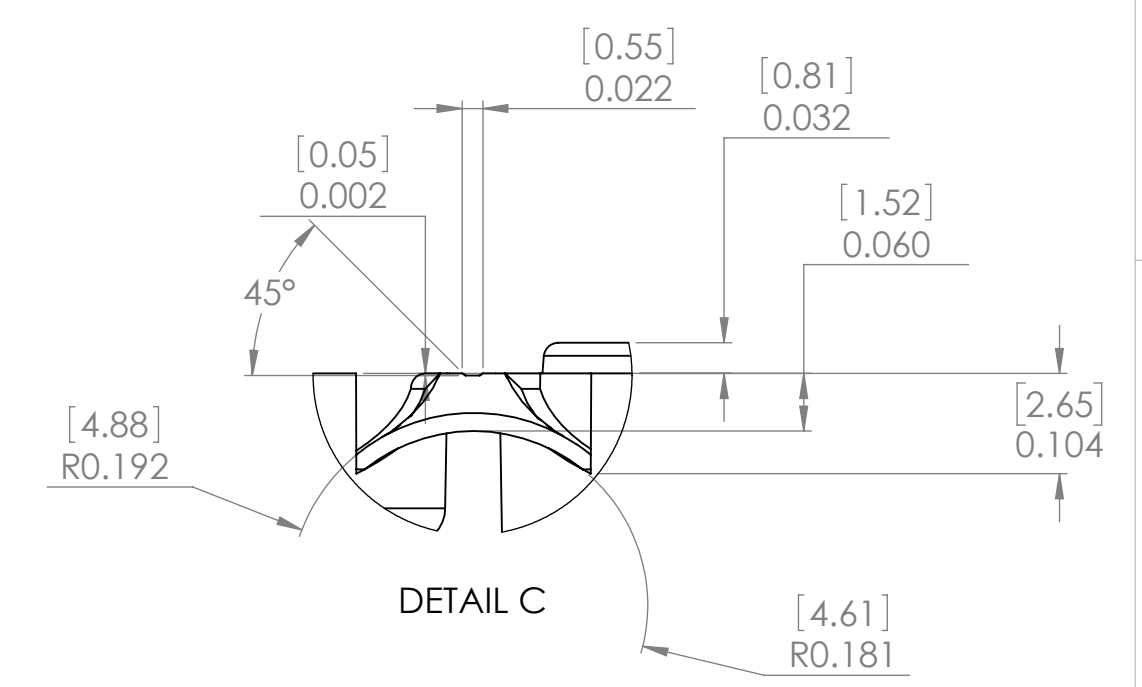
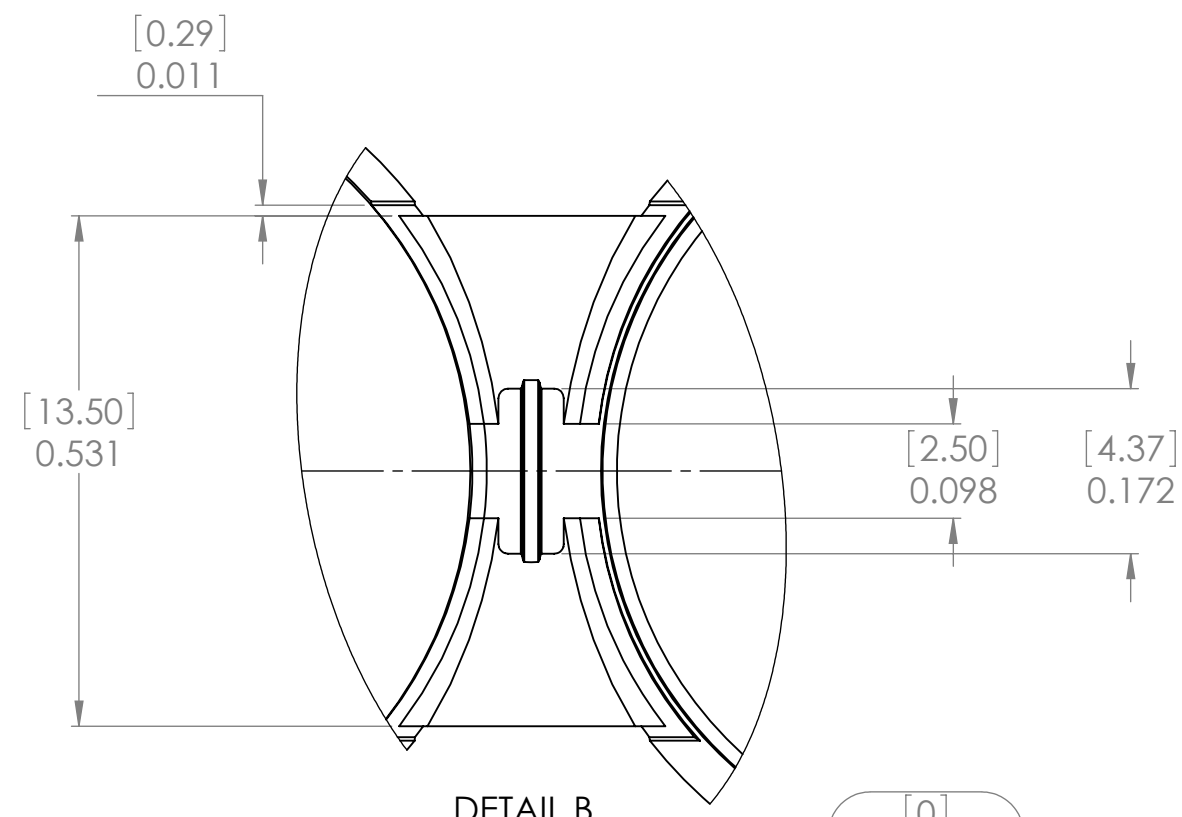
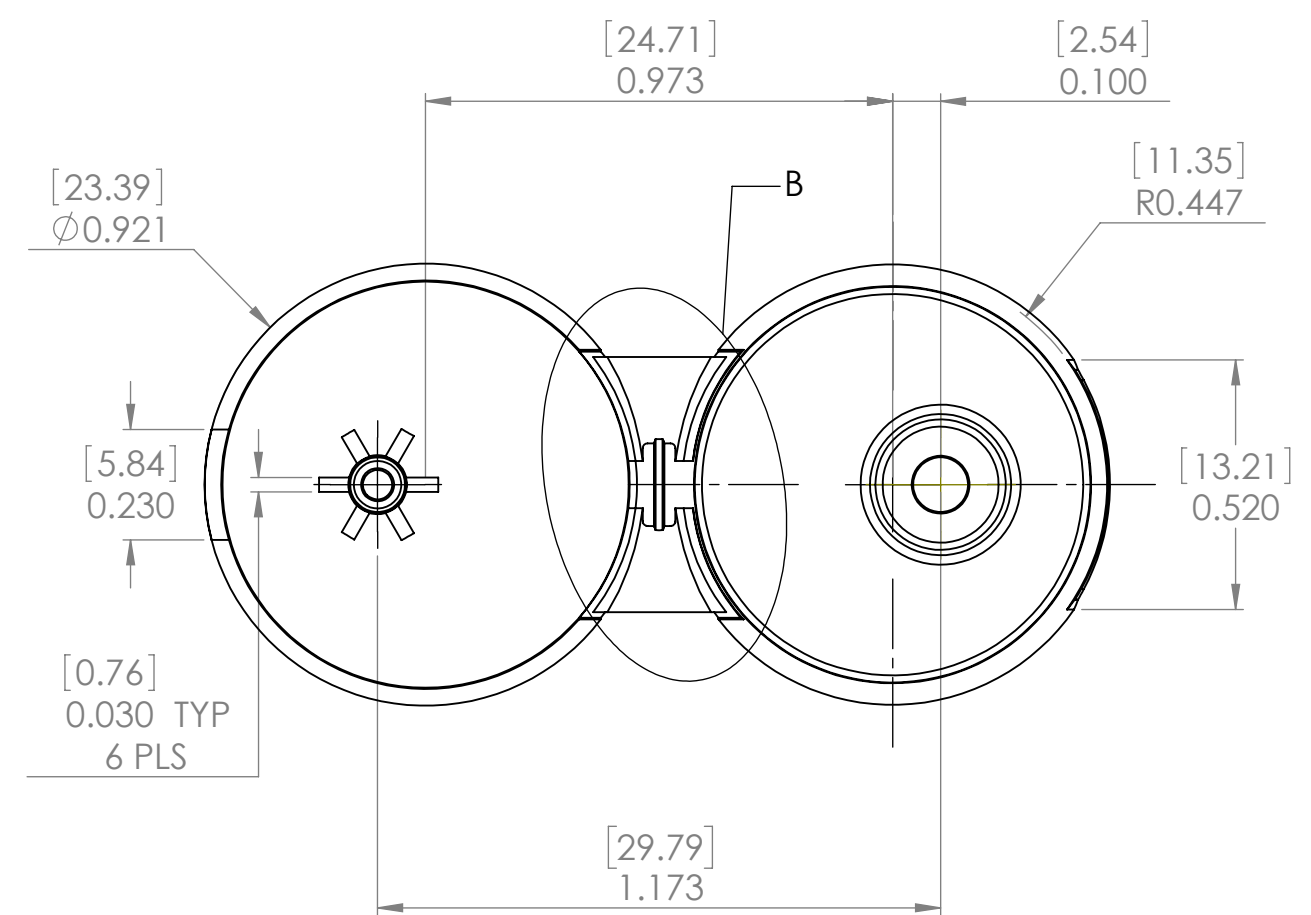

- Notes:
1. Dimensions in parenthesis are in millimeters.
  2. 1 Degree TPS (Taper Per Side) inside and outside unless otherwise specified.
  3. Minimum Radius R0.005 [0.13] all sharpe edges unless otherwise specified.
  4. Engrave all cavity ID numbers in 6 PT STD x 0.003 [0.08] deep in specified location or cavity ID marks to be vapor blasted on stripper ring @ 0.010 [0.25] maximum width.
  5. Bordered dimensions are QC (Quality Control) dimensions.
  6. All surfaces to be SPI A-2 High Polish

GENERAL TOLERANCES UNLESS OTHERWISE SPECIFIED:		NAME	DATE
< .200	$\pm$ .003	DRAWN	C.WILLIS 8-07-19
.200 - .600	$\pm$ .004	CHECKED	
.600 - 2.000	$\pm$ .006	ENG APPR.	
2.000 - 4.000	$\pm$ .008	MFG APPR.	
> 4.00	$\pm$ .012	Q.A.	

WEIGHT		MATERIAL	PP
OFC		FINISH	
		DO NOT SCALE DRAWING	

TITLE:	20-410 Fliptop Closure	SIZE	DWG. NO. C PSG20-006-11
		SCALE: 5:1	SHEET 1 OF 1

