

4

3

2

1

A-A

REVISIONS

ZONE	REV	DESCRIPTION	DATE	APPROVED

F

E

D

C

B

A

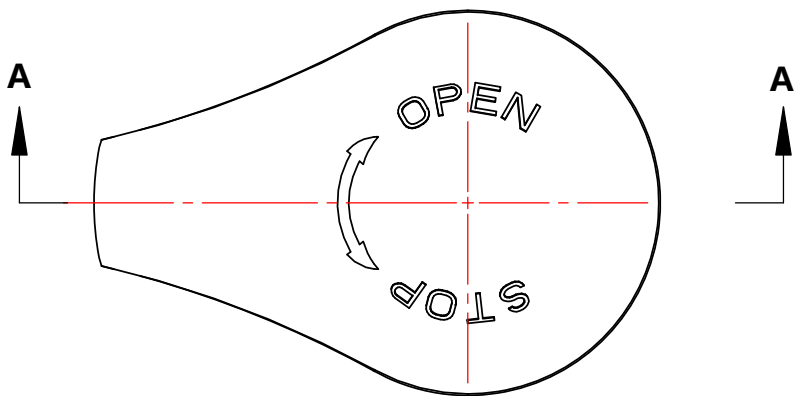
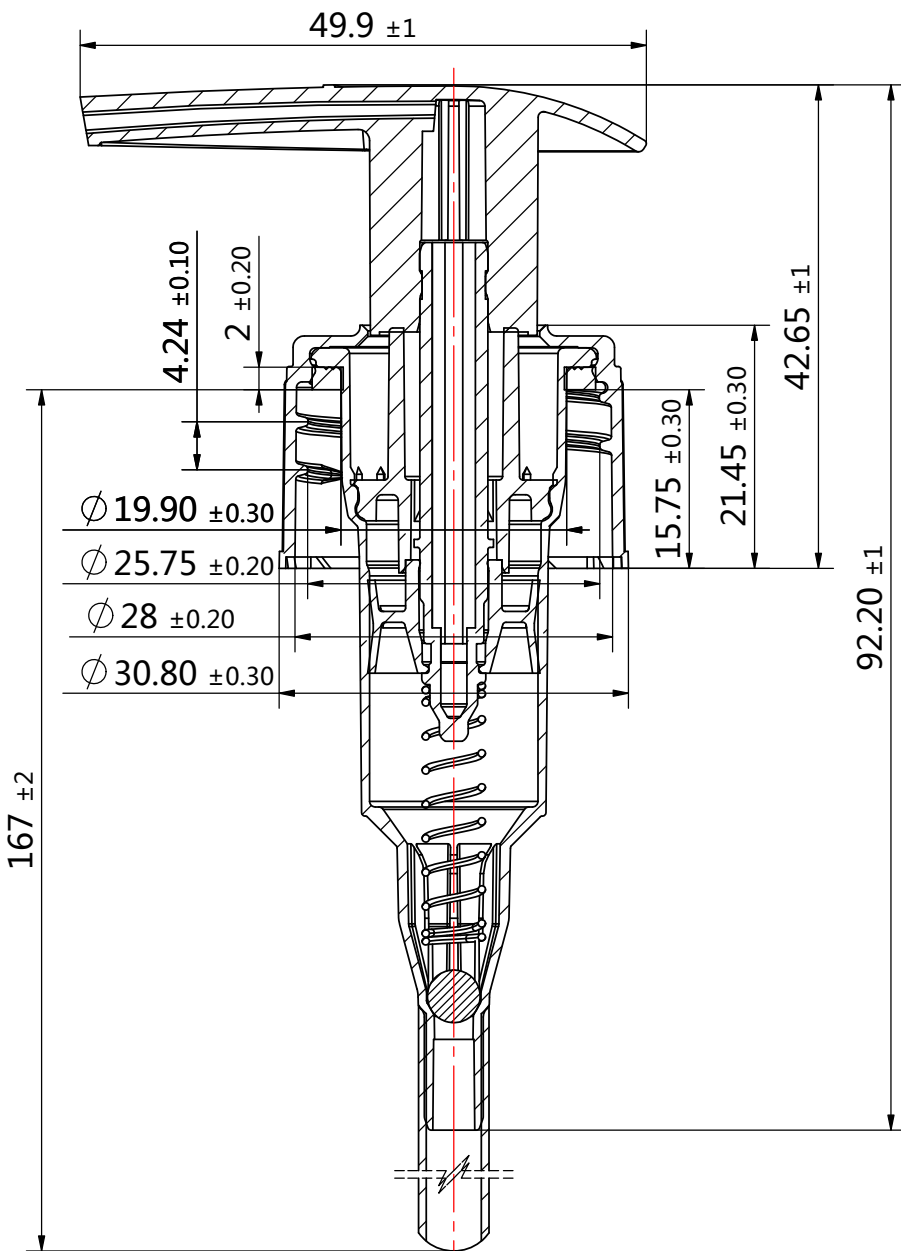

Stocksize :

Treatment :

Finish :



Name

Date

Plastic Product Department

Weight :

Designer

梁金考

2020-4-23

Deburr and Break Sharp Edges

Dimensions are in Millimeters

Scale : 3:2

A4

Description

Surface Finish:

Sheet 1 of 1

Part Code:

PAE03-28/410-167

Chk'd

张永春

2020.04.23
15:56:35
+08'00'

Tolerances:

First Angle

Revision

File Name

2.0cc

Quantity

Appv'd

According to the tolerance level TG3/TG4 in DIN16742
按DIN16742中的公差等级TG3/TG4

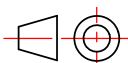

Material

/