

4

3

2

1

## REVISIONS

ZONE	REV.	DESCRIPTION	DATE	APPROVED
------	------	-------------	------	----------

A-A

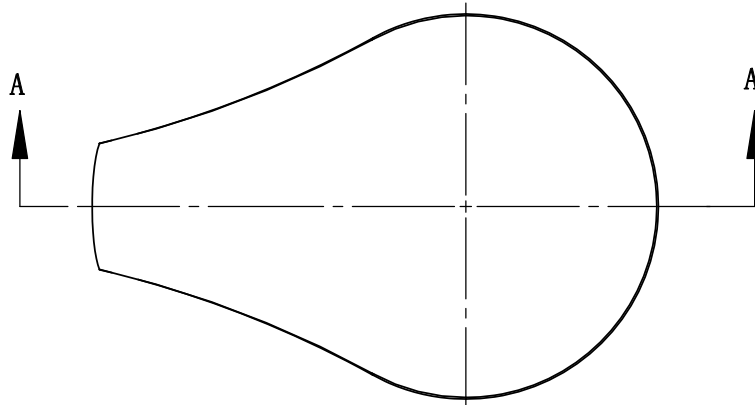
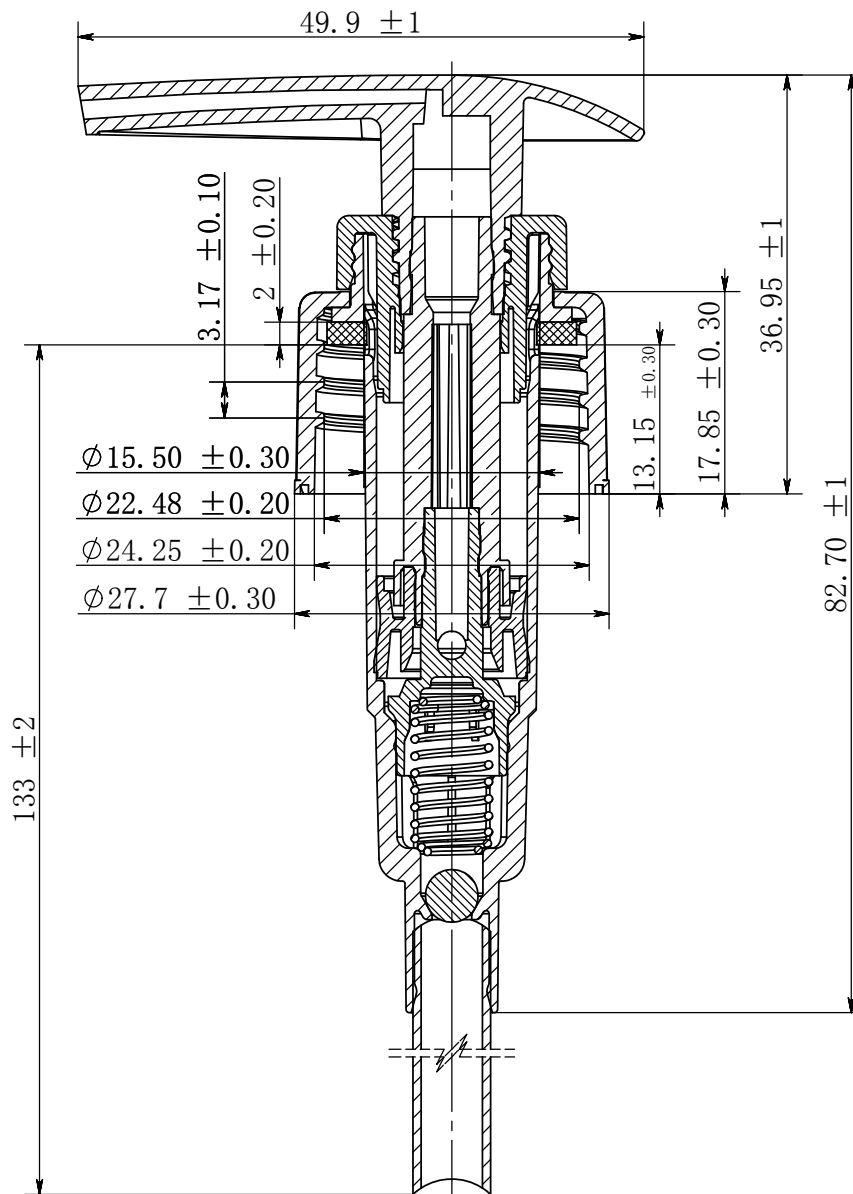

Stocksize /		Treatment: /		Finish: /		<b>PSG</b>	
Name	Date	Plastic Product Department		Weight: /			
Designer	梁金考	2020-4-23	Deburr and Break Sharp Edges		Scale: 3:2	Description	
Chk'd	张永春	2020.04.23	Dimensions are in Millimeters		Sheet 1 of 1	Part Code: P2330-24/410-133	
Appv'd			Surface Finish:		First Angle	Revision	File Name
			Tolerances:			A	2.0cc
			According to the tolerance level TG3/TG4 in DIN16742 按DIN16742中的公差等级TG3/TG4				Material
							/
							/