

THIS REGISTERED DESIGN IS THE PROPERTY OF PSG AND IS NOT TO BE REPRODUCED, DISCLOSED TO A THIRD PARTY OR COPIED WITHOUT PRIOR WRITTEN PERMISSION.

| REVISION |  |        |         |
|----------|--|--------|---------|
| REV      | DESCRIPTION  | REV BY | DATE    |
| 2        | UPDATED DECO LUGS, UPDATED ENGRAVINGS, ADDED TOLERANCING AND PREFORM CAVITY ID | CCW    | 6-11-20 |
| 3        | .913 WAS .923, Ø.717 WAS Ø.688   | CCW    | 6-30-20 |

F  
E  
D  
C  
B  
A

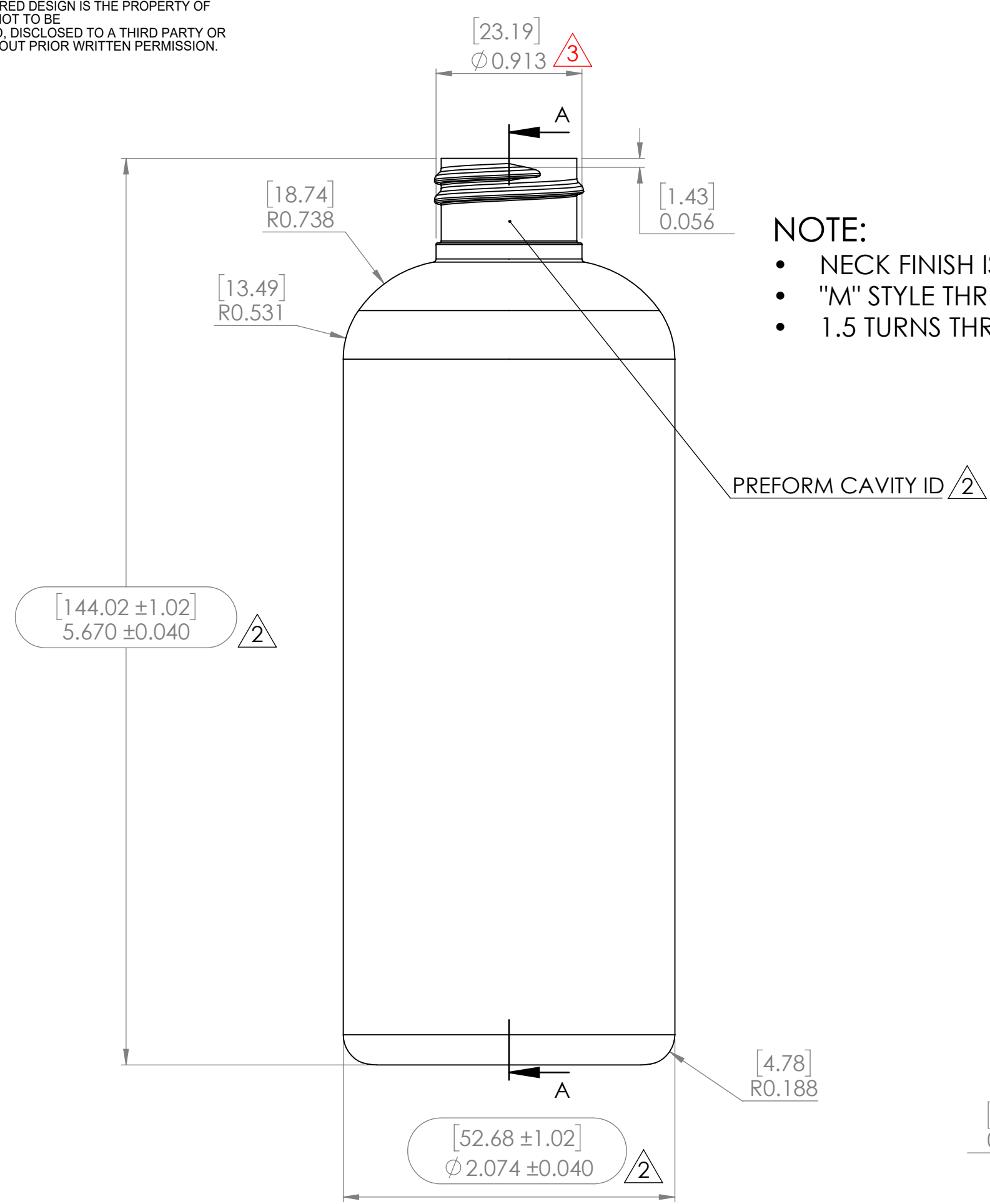

**NOTE:**

- NECK FINISH IS SPI 24-410
- "M" STYLE THREADS
- 1.5 TURNS THREAD

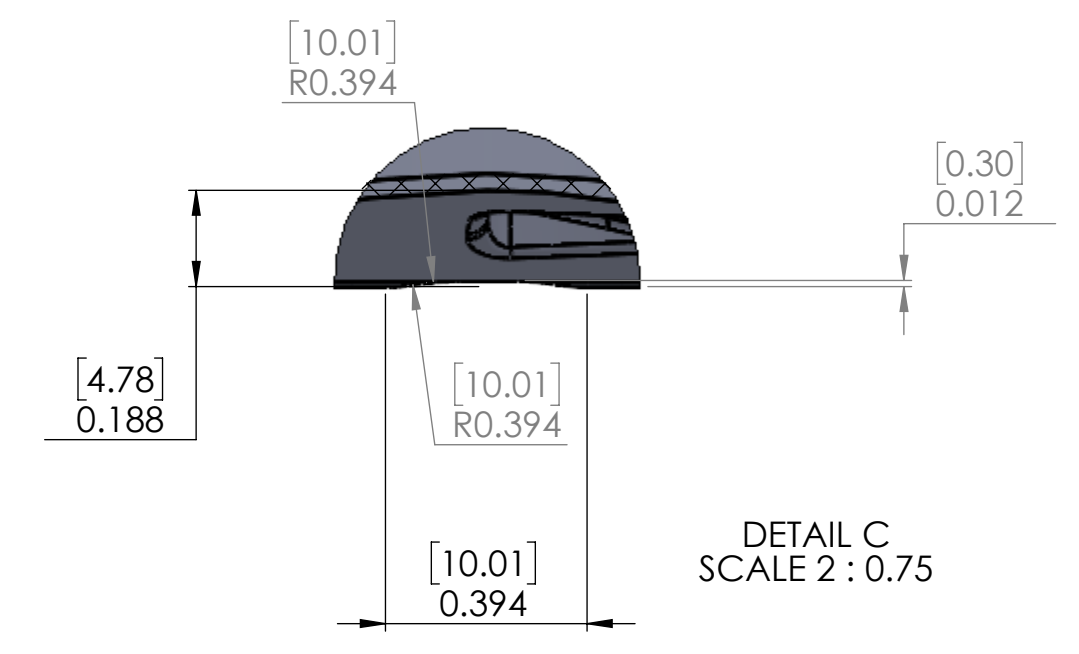
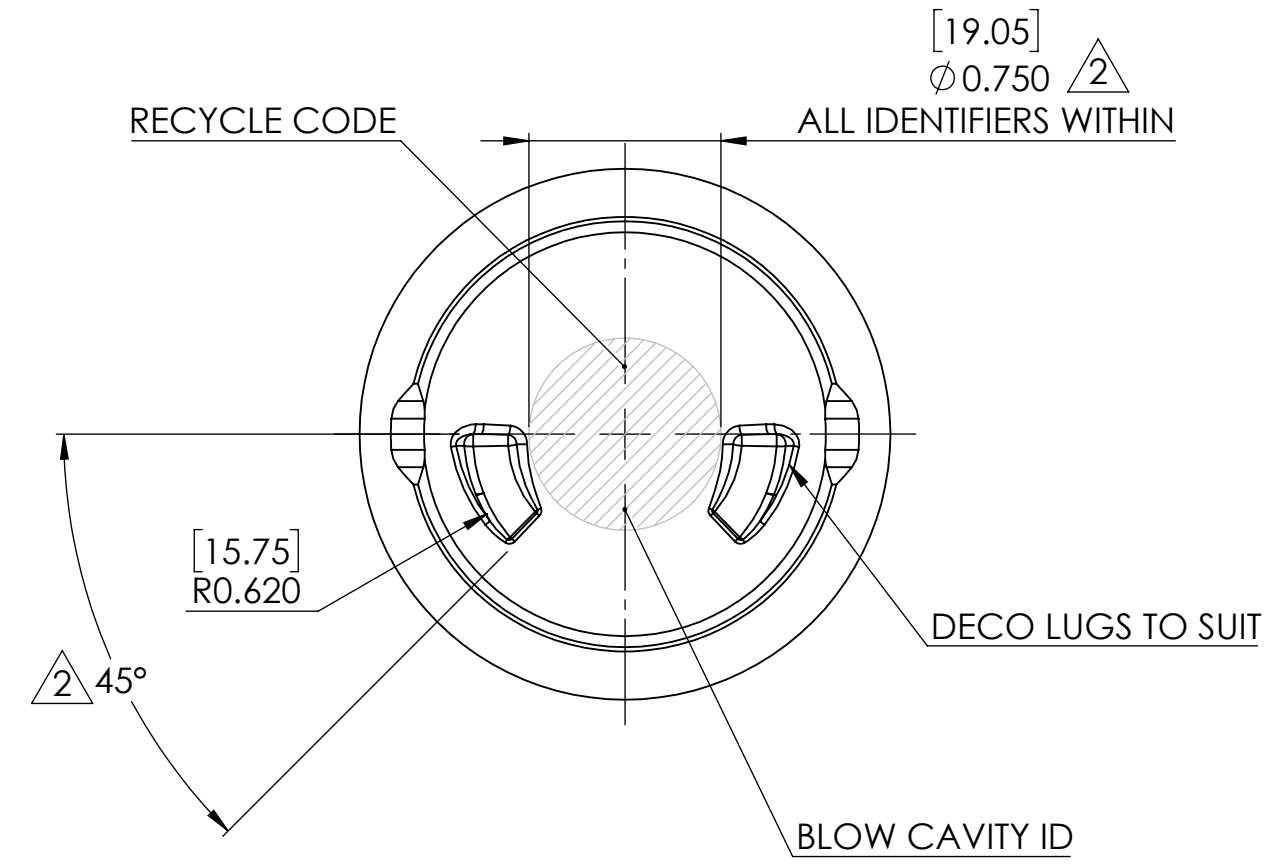
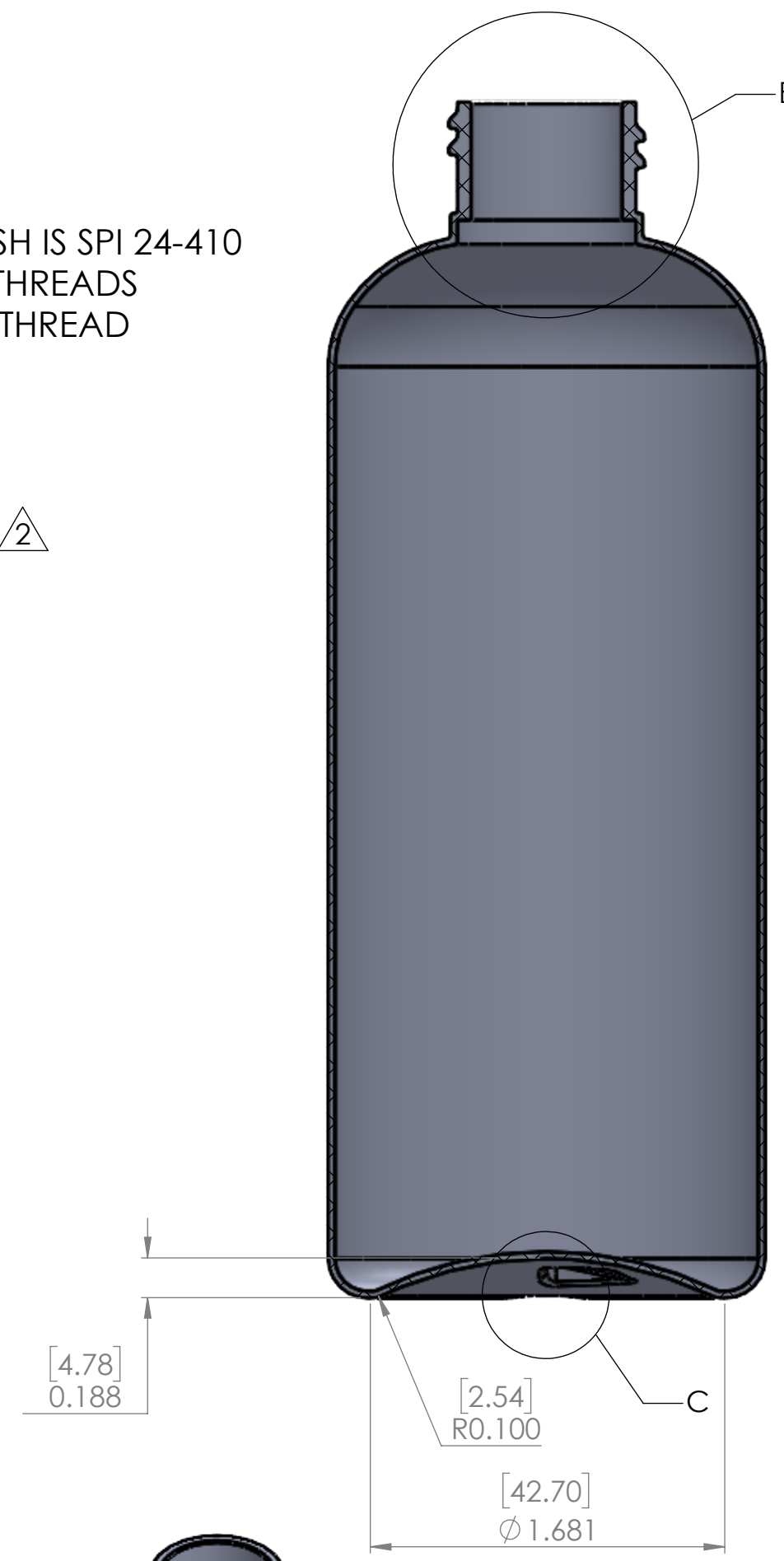

**Notes:**

1. Dimensions in parenthesis are in millimeters.
2. 1 Degree TPS (Taper Per Side) inside and outside unless otherwise specified.
3. Minimum Radius R0.005 [0.13] all sharpe edges unless otherwise specified.
4. Engrave all cavity ID numbers in 6 PT STD x 0.003 [0.08] deep in specified location or cavity ID marks to be vapor blasted on stripper ring @ 0.010 [0.25] maximum width.
5. Bordered dimensions are QC (Quality Control) dimensions.
6. All surfaces to be SPI A-2 High Polish

| GENERAL TOLERANCES UNLESS OTHERWISE SPECIFIED: |        | NAME      | DATE             |
|--|--------|-----------|------------------|
| < .200   | ± .003 | DRAWN     | C.WILLIS 6-02-20 |
| .200 - .600                                    | ± .004 | CHECKED   |                  |
| .600 - 2.000                                   | ± .006 | ENG APPR. |                  |
| 2.000 - 4.000                                  | ± .008 | MFG APPR. |                  |
| > 4.000  | ± .012 | Q.A.      |                  |

|                      |                |          |     |        |                       |
|----------------------|----------------|----------|-----|--------|-----------------------|
| WEIGHT               | 20.5g +/-1.5g  | MATERIAL | PET | TITLE: | 8oz BOSTON ROUND      |
| OFC                  | 250ml +/-7.0ml | FINISH   |     | SIZE   | DWG. NO. PSG20-018-13 |
| DO NOT SCALE DRAWING |                |          |     | SCALE: | 1:2                   |

PSG

SHEET 1 OF 1